



SUBMERSIBLE RANGE

C-SERIES RAW SEWAGE



24-01

C-SERIES SUBMERSIBLE RANGE

Raw Sewage: 1.1 - 7.5kW



Design

The C Range of raw sewage / sludge pumps feature an adjustable bottom plate to maintain efficiency by maintaining the preferred clearance in relation to the channel impeller. The inlet opening is shaped like a star and grabs stringy solids entering the pump. As the open vane impeller rotates, it effectively cuts all stringy solids (held by the inlet plate) to manageable sizes, before

allowing access to the pump volute.

Performance range

Maximum Head: 30m
 Maximum Flow: 120m³/h
 Power: 1.1 - 7.5kW
 Motor Speed: 2 Pole

Operating conditions

Liquid temperature: up to 40°C
 Density of liquid: 1.3g/cm³
 PH: 6 to 10
 Protection class: P68, Class B
 Maximum immersion depth: 10m
 Cable length: 8m

Materials of construction

Cast iron pump construction.
 Cast iron impeller construction, open type single channel.
 Integrated cutter mechanism located on pump inlet.
 Double mechanical shaft seal (silicon carbide-silicon carbide/carbon graphite-ceramic).



Static Ripper Plate



Duckfoot

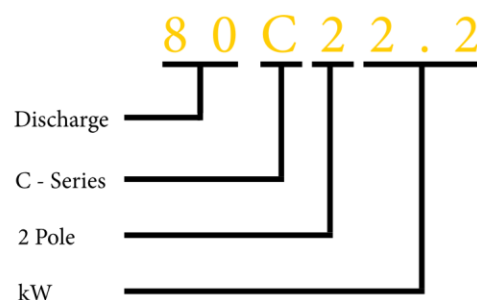

MODEL	VOLTAGE	CURRENT	MOTOR POWER		OUTLET		MAX FLOW	MAX HEAD	IMPELLER PASSAGE	CABLE
	V	A	kW	HP	INCH	MM	m ³ /h	m	mm	mm ²
50C21.1S	220	7.2	1.1	1.5	2	50	27	15	20	3G1.0
50C21.1	380	2.8	1.1	1.5	2	50	27	15	20	4G1.0
50C21.5	380	3.2	1.5	2	2	50	31	13	40	4G1.0
50C22.2	380	5	2.2	3	2	50	35	17	40	4G1.0
80C23.0	380	6.5	3.0	4	3	80	67	21	30	4G1.5
80C24.0	380	8.9	4.0	5.5	3	80	79	24	30	4G1.5
100C25.5	380	11.7	5.5	7.5	4	100	107	27	35	4G2.5
100C27.5	380	15.7	7.5	10	4	100	135	30	50	4G2.5

PERFORMANCE CURVE

PERFORMANCE CURVE & DIMENSIONS

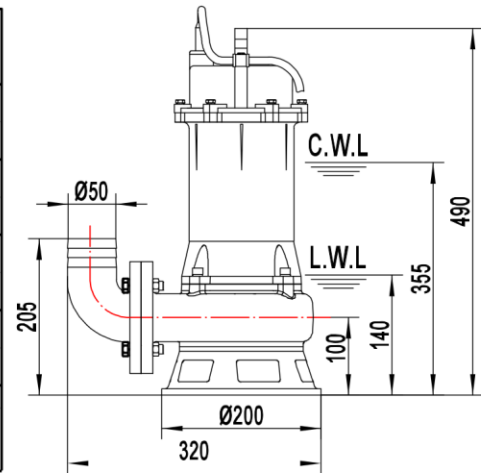
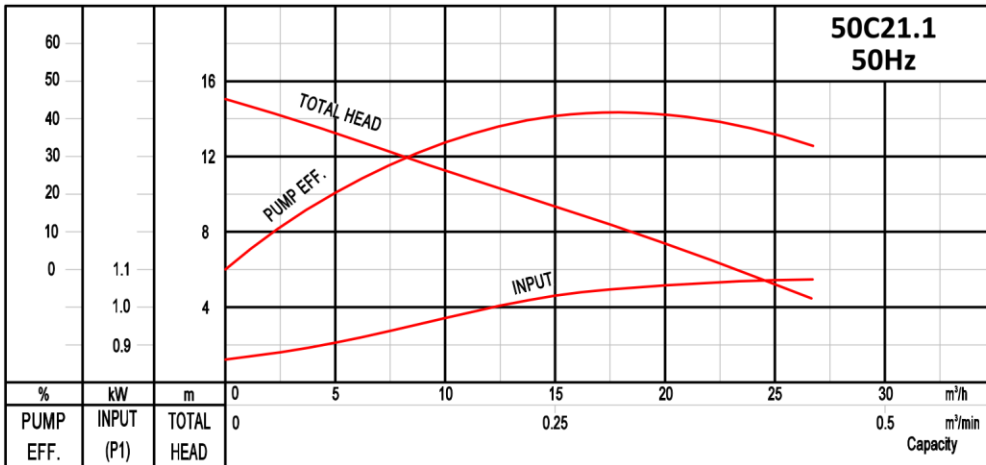

WEIGHT 29KG

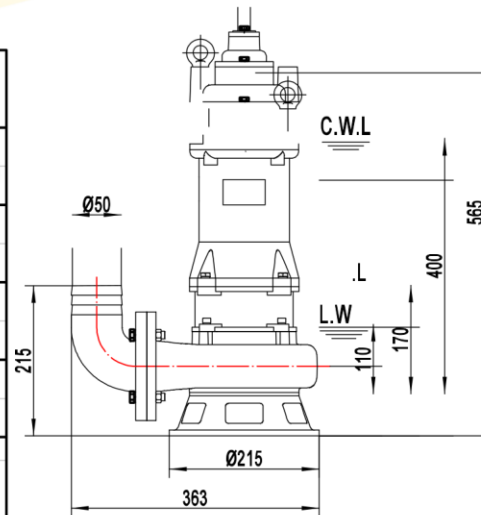
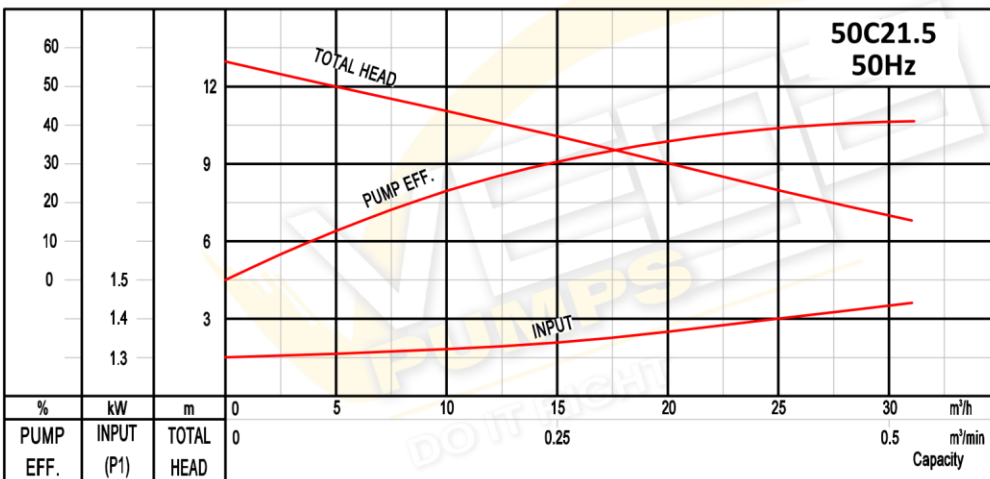

WEIGHT 39KG

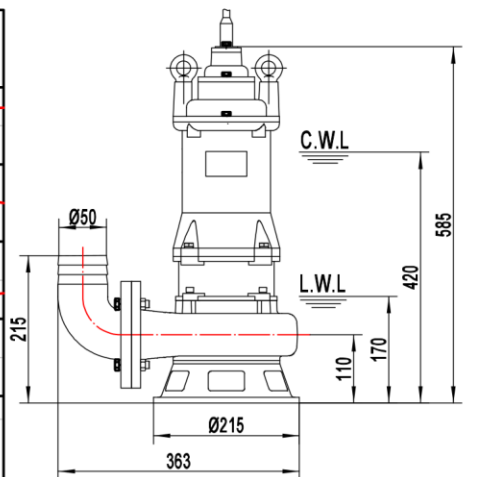
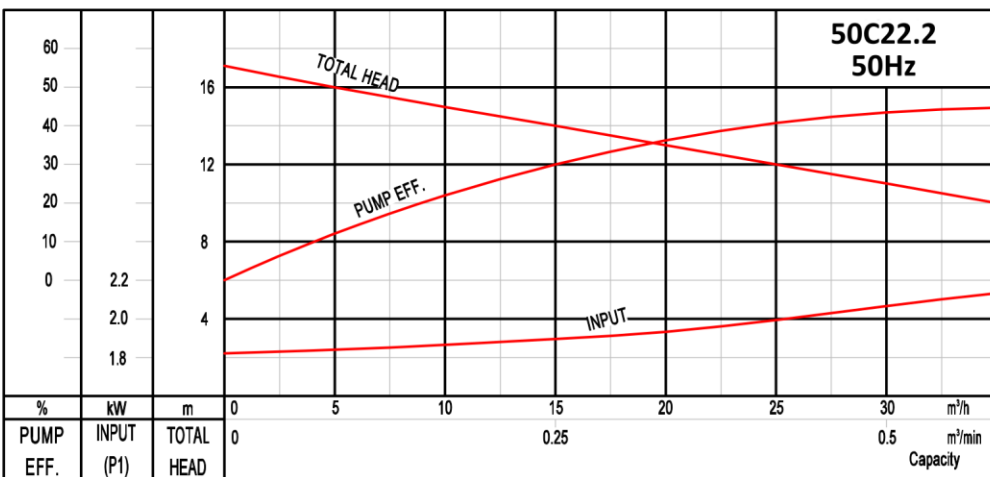

WEIGHT 41KG

PERFORMANCE CURVE

PERFORMANCE CURVE & DIMENSIONS

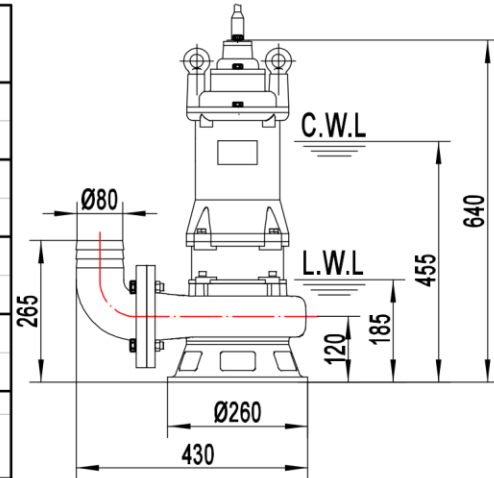
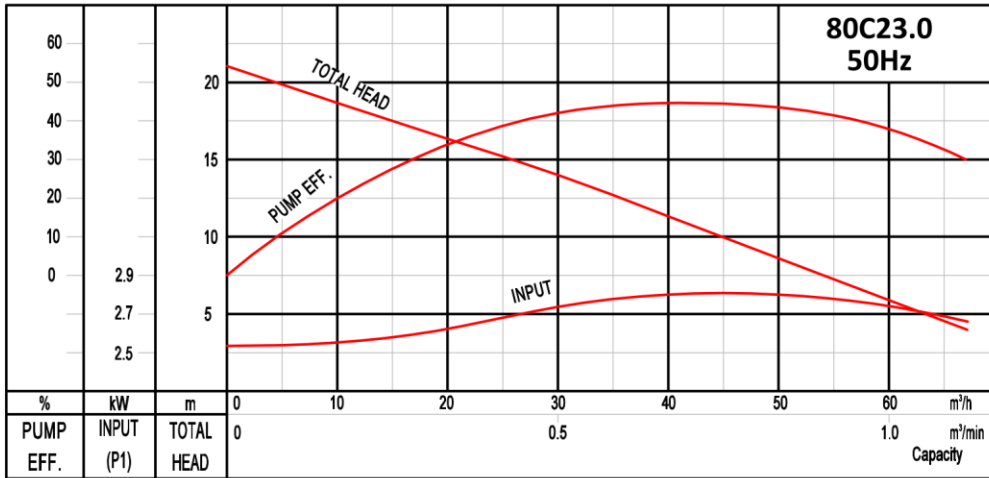

WEIGHT 56KG

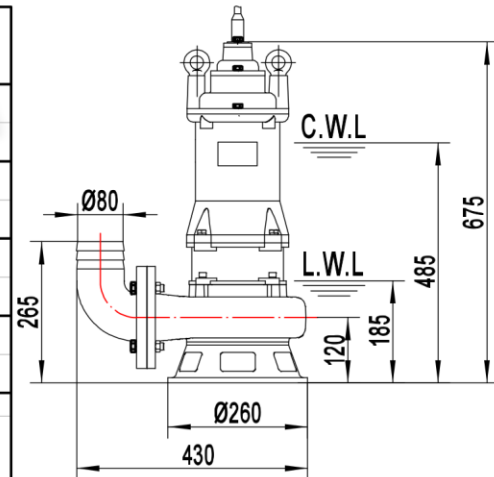
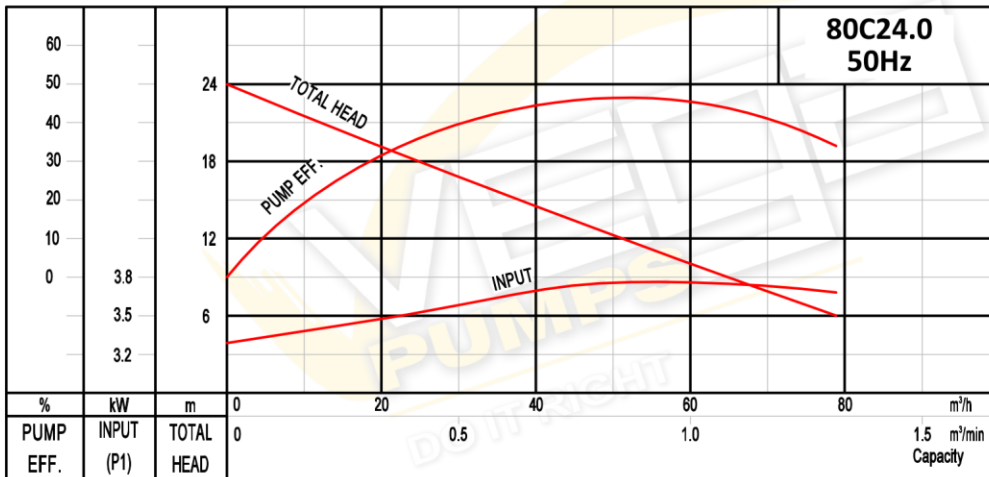

WEIGHT 64KG

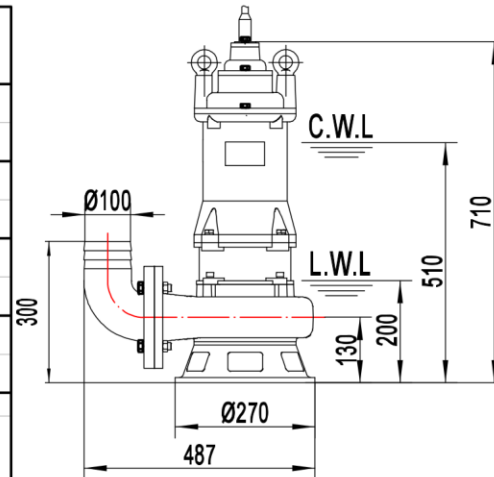
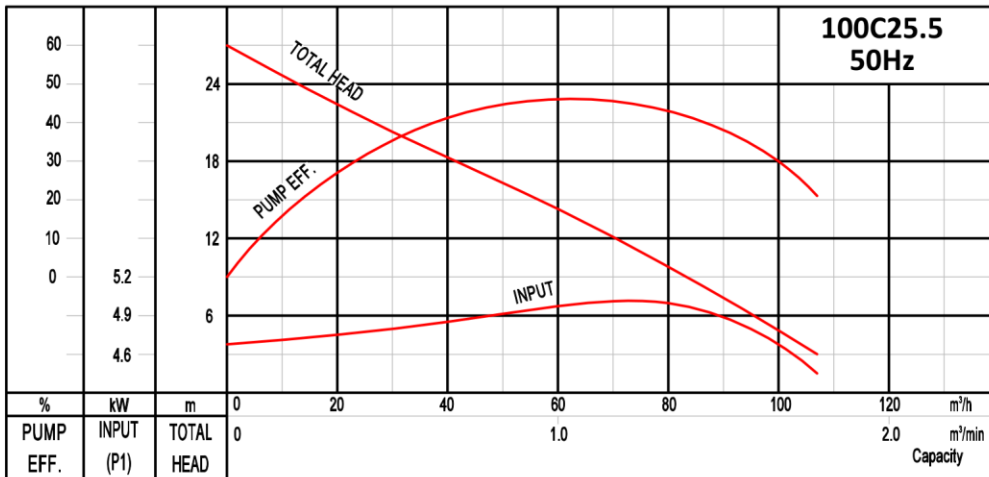

WEIGHT 83KG

PERFORMANCE CURVE

PERFORMANCE CURVE & DIMENSIONS

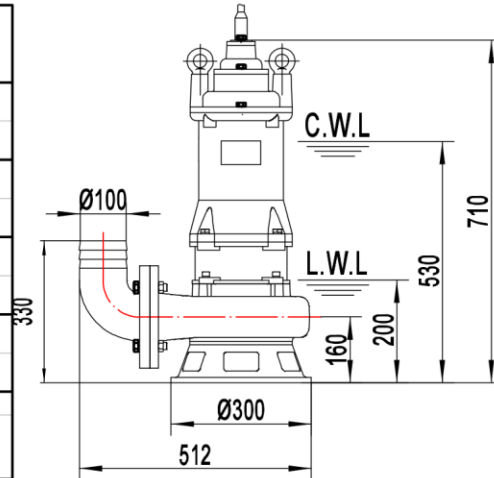
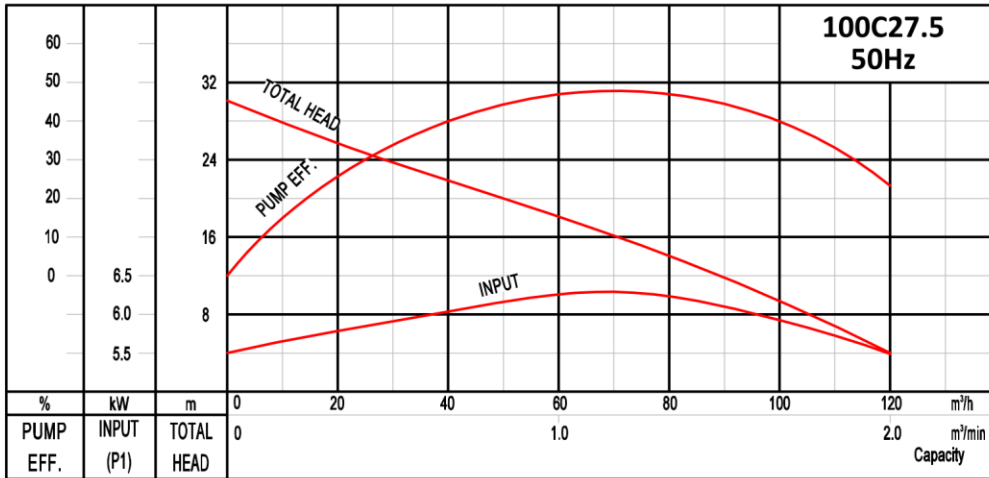

WEIGHT 95KG

EXPLODED VIEW

Index	Part name	Qty	Material
01	Hose coupling	1	Cast iron
03	Terminal box	1	Cast iron
05	Upper cover	1	Cast iron
07	Bearing house	1	Cast iron
11	Motor body	1	Cast iron
13	Pump body	1	Cast iron
14	Impeller	1	Cast iron
16	Inlet plate	1	Ductile iron
21	Cable tube	1	NBR
22	Seat assembly	1	Cast iron
27	Stator	1	
28	Rotor	1	
31a	Bearing	1	
31b	Bearing	1	
33	Motor protector	1	
34	Mechanical seal	1	Sic-Sic/Car-Cer
35	Oil seal	1	
36a	O-ring	1	NBR
36b	O-ring	2	NBR
36c	O-ring	1	NBR
36d	O-ring	1	NBR
36e	O-ring	1	NBR
36f	O-ring	1	NBR
37a	Gasket	0 - 3	PVC
37b	Gasket	1	NBR
41a	Bearing fixing plate	1	
41b	Mechanical Seal fixing plate	1	

Index	Part name	Qty	Material
41c	Pressing block	1	
42a	Bolt	4	AISI304SS
42b	Bolt	4	AISI304SS
42c	Screw	2	
42d	Screw	2	AISI304SS
42e	Screw	2	
42f	Screw	1	
42g	Bolt	4	AISI304SS
42h	Bolt	4	
42i	Bolt	4	
42j	Screw	3	
42k	Screw	1	AISI304SS
42L	Bolt	4	AISI304SS
42m	Bolt	4	
43a	Nut	1	
43b	Nut	4	
44a	Spring washer	12	AISI304SS
44b	Spring washer	8	AISI304SS
44c	Washer	1	AISI304SS
44d	Wave pad	1	65Mn
44e	Spring washer	4	
44f	Spring washer	1	AISI304SS
44g	Spring washer	4	
45	Key	1	AISI304SS
46	Circlips for holes	1	65Mn
47	Cable	1	
47	Cable assembly	1	

C-SERIES SUBMERSIBLE RANGE

EXPLODED VIEW

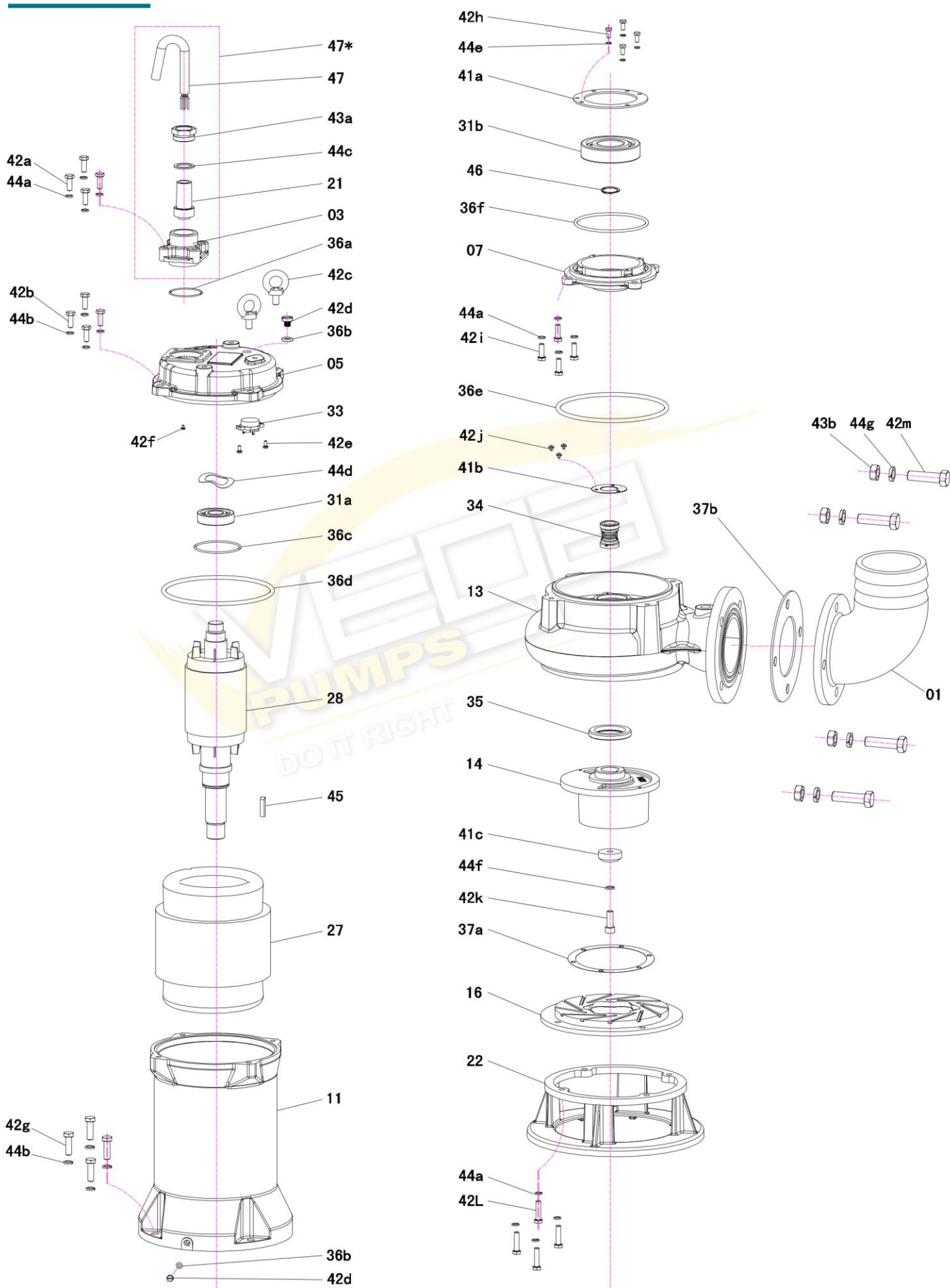

TECHNICAL INFORMATION



Movable Soft Pipe Installation (R)

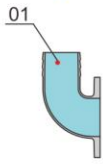

Movable Hard Pipe Installation(Y)

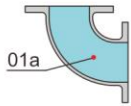

Auto-coupled Installation (Z)

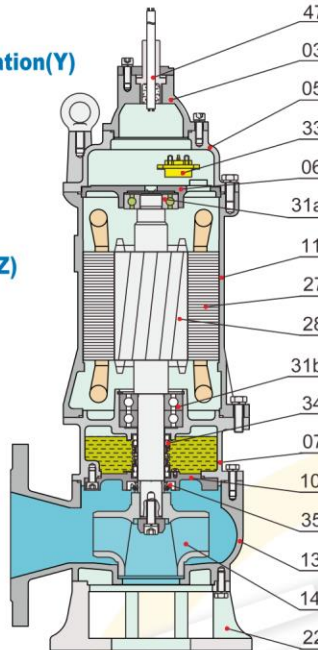
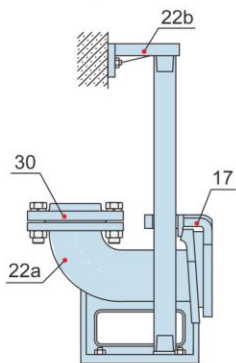

ITEM No.	PART NAME	MATERIAL
01	HOSE COUPLING	CAST IRON
01a	HOSE COUPLING	CAST IRON
03	TERMINAL BOX	CAST IRON
05	UPPER COVER	CAST IRON
06	UP-BEARING HOUSE	CAST IRON
07	BEARING HOUSE	CAST IRON
11	MOTOR BODY	CAST IRON
13	PUMP BODY	CAST IRON
14	IMPELLER	CAST IRON
16	INLET PLATE	CAST IRON
17	COUPLING ADAPTER	CAST IRON
22	SEAT ASSEMBLY	CAST IRON
22a	COUPLING SEAT	CAST IRON
22b	UPPER GUIDE SUPPORT	CAST IRON
27	STATOR	
28	ROTOR	SHAFT: AISI304SS
30	FLANGE	CAST IRON
31a	BEARING	BALL BEARING
31b	BEARING	BALL BEARING
33	MOTOR PROTECTOR	
34	MECHANICAL SEAL	SIC-SIC/CARBON-CERAMIC
35	OIL SEAL	
47	CABLE	

Weights & Packing Dimensions

MODEL	N.W	G.W	PACKING DIMENSIONS
	kg	kg	mm
50C21.1	27	28.5	540*245*250
50C21.5	39	43.5	680*250*325
50C22.2	46	50.5	700*250*325
80C23.0	56	62	760*300*355
80C24.0	64	70	800*300*355
100C25.5	83	89	830*320*355
100C27.5	95	105	834*314*400